

Owner's Manual



AIR COMPRESSOR

2-gallon

1HP

Oil Lubricated

Model No. 921.153120

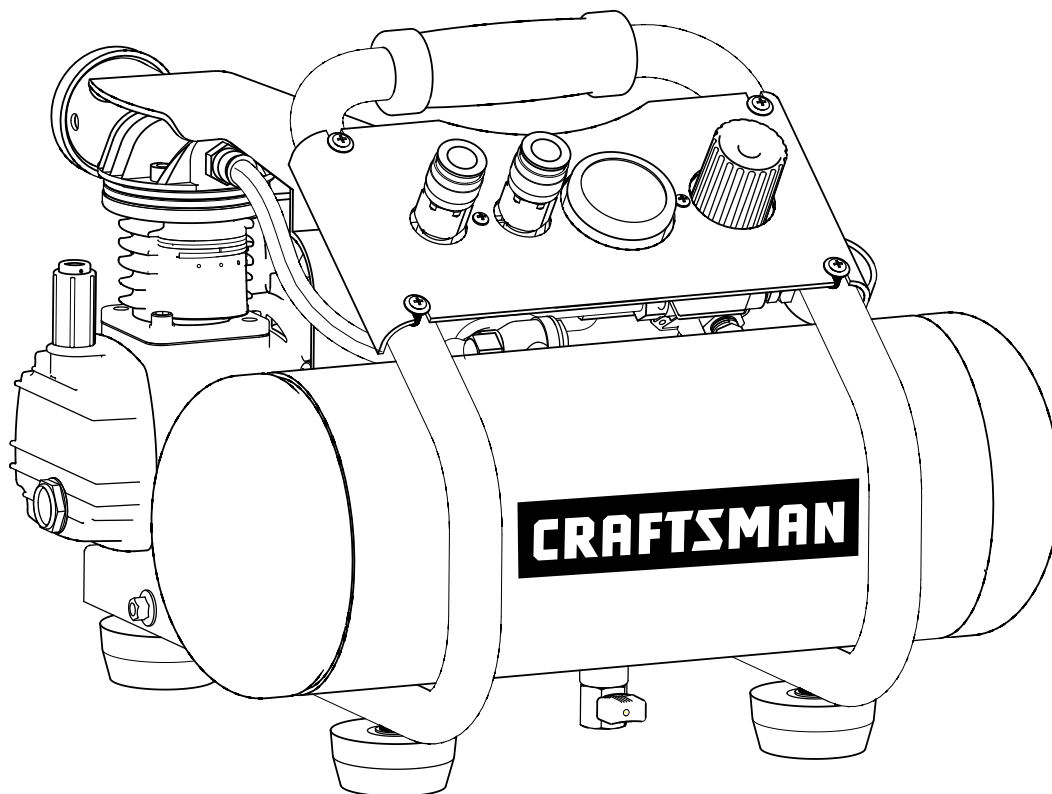

CAUTION:

**Before using this product,
read this manual and follow
all its Safety Rules and
Operating Instructions.**

- **Safety Instructions**
- **Installation & Operation**
- **Maintenance & Storage**
- **Troubleshooting Guide**
- **Parts List**
- **Español, p. 10**

Sears, Roebuck and Co., Hoffman Estates, IL 60179 U.S.A.
www.sears.com

Table of Contents

	Page
Warranty	See Below
Safety Symbols	1
Important Safety Instructions & Guidelines	1
Specifications	2
Glossary	2
Duty Cycle	2
Parts & Features	3
Installation & Assembly	4
Operating Procedures	5
Detaching Unit from Dolly	6
Maintenance	6
Storage	6
Troubleshooting Guide	7
Exploded View	8
Parts List	9
Español	10

ONE YEAR FULL WARRANTY ON CRAFTSMAN AIR COMPRESSOR

If this Craftsman Air Compressor fails due to manufacturer's defects in material or workmanship within one year of the date of purchase, RETURN IT TO THE NEAREST SEARS STORE OR SERVICE CENTER IN THE UNITED STATES and it will be replaced or repaired (at our option), free of charge.

If this Air Compressor is used for commercial or rental purposes, this warranty applies for only 90 days from the date of purchase. This warranty gives you specific legal rights and you may also have other rights which vary from state to state.

**Sears, Roebuck and Co., Dept. 817WA,
Hoffman Estates, IL 60179**

Safety Symbols

The information listed below should be read and understood by the operator. This information is given to protect the user while operating and storing the air compressor. We utilize the symbols below to allow the reader to recognize important information about their safety.

<p align="center">⚠ DANGER</p> <p>Indicates an imminently hazardous situation which, if not avoided, will result in death or serious injury.</p>	<p align="center">⚠ CAUTION</p> <p>Indicates a potentially hazardous situation which, if not avoided, may result in minor or moderate injury.</p>
<p align="center">⚠ WARNING</p> <p>Indicates a potentially hazardous situation which, if not avoided, could result in death or serious injury</p>	<p align="center">CAUTION</p> <p>When used without the safety alert symbol indicates a potentially hazardous situation which, if not avoided, may result in property damage.</p>





Important Safety Instructions and Guidelines





- Save all instructions

⚠ WARNING

WARNING: This product contains one or more chemicals known to the State of California to cause cancer and birth defects or other reproductive harm.
Wash hands after handling.

Improper operation or maintenance of this product could result in serious injury and/or property damage. Read and understand all of the warnings and safety instructions provided before using this equipment.

<p align="center">CAUTION</p>	<p>The air compressor should be operated on a dedicated 15 amp circuit. If the circuit does not have 15 free amps available, a larger circuit must be used. Always use more air hose before utilizing extension cords. All extension cords used must be 12 gauge with a maximum length of 25 ft. The circuit fuse type must be a time delay. Low voltage could cause damage to the motor.</p>
<p>Risk of Moving Parts</p> 	<p>If the air compressor is in operation, all guards and covers should be attached or installed correctly. If any guard or cover has been damaged, do not operate the equipment until the proper personnel has correctly repaired the equipment. The power cord should be free of any moving parts, twisting and/or crimping while in use and while in storage.</p>
<p>Risk of Burns</p> 	<p>There are surfaces on your air compressor that while in operation and thereafter can cause serious burns if touched. The equipment should be allowed time to cool before any maintenance is attempted. Items such as the compressor pump and the outlet tube are normally hot during and after operation.</p>
<p>Risk of Falling</p> 	<p>Operation of the air compressor should always be in a position that is stable. Never use the air compressor on a rooftop or elevated position that could allow the unit to fall or be tipped over. Use additional air hose for elevated jobs.</p>
<p>Risk from Flying Objects</p> 	<p>Always wear ANSI Z87.1 approved safety glasses with side shields when the air compressor is in use. Turn off the air compressor and drain the air tank before performing any type of maintenance or disassembly of the hoses or fittings. Never point any nozzle or sprayer toward any part of the body or at other people or animals.</p>

<p>Risk of Breathing</p> 	<p>Avoid using the air compressor in confined areas. Always have adequate space (12 inches) on all sides of the air compressor. Also keep children, pets, and others out of the area of operation. This air compressor does not provide breathable air for anyone or any auxiliary breathing device. Spraying material will always need to be in another area away from the air compressor to not allow intake air to damage the air compressor filter.</p>
<p>Risk of Electrical Shock</p> 	<p>Never utilize the air compressor in the rain or wet conditions. Any electrical issues or repairs should be performed by authorized personnel such as an electrician and should comply with all national and local electrical codes. The air compressor should also have the proper three prong grounding plug, correct voltage, and adequate fuse protection.</p>
<p>Risk of Explosion or Fire</p> 	<p>Never operate the compressor near combustible materials, gasoline or solvent vapors. If spraying flammable materials, locate the air compressor at least 20 feet away from the spray area. Never operate the air compressor indoors or in a confined area.</p>
<p>Risk of Bursting</p> 	<p>Always drain the air compressor tank daily or after each use. If the tank develops a leak, then replace the air compressor. Never use the air compressor after a leak has been found or try to make any modifications to the tank. Never modify the air compressor's factory settings which control the tank pressure or any other function.</p>

Specifications

Pump	Oil-lube direct drive	Air Tank Capacity	2 Gallons
Motor	1.0 HP (Induction)	Cut-in Pressure95 PSI
Bore	1.65"	Cut-out Pressure	125 PSI
Stroke	1.26"	SCFM @ 90 PSI	2.4
Voltage Single Phase	120 VAC	Oil Capacity	90 mL or 3 oz.
Minimum Circuit Requirement	15 Amps	Oil Type	SAE 30 Non-detergent

Glossary

CFM: Cubic feet per minute.

SCFM: Standard cubic feet per minute; a unit of measure for air delivery.

PSIG: Pounds per square inch gauge; a unit of measure for pressure.

ASME: American Society of Mechanical Engineers.

California Code: Unit may comply with California Code 462 (I) (2)/ (M) (2).

Cut-In Pressure: The air compressor will automatically start to refill the tank when the pressure drops below the prescribed minimum.

Cut-Out Pressure: The point at which the motor stops when the tank has reached maximum air pressure.

Code Certification: Products that bear one or more of the following marks: UL, ULc, ETL, CSA, have been evaluated by OSHA-certified independent safety laboratories and meet the applicable Underwriters Laboratories Standards for Safety.

Duty Cycle

This is a 50% duty cycle air compressor. Do not run the air compressor more than 30 minutes of one hour. Doing so could damage the air compressor.

Parts & Features

See figures below for reference.

Check Valve

When the pump is not in operation the valve closes to retain air pressure inside the tank. An internal component.

Quick Connect

Offers a quick release feature for attaching and removing the air hose.

Regulator Gauge

Indicates the outgoing air pressure to the tool and is controlled by the regulator.

Regulator

The air pressure coming from the air tank is controlled by the regulator. To increase the pressure turn the knob clockwise and to decrease the pressure turn the knob counterclockwise.

Pressure Switch

This controls the power to the motor and also the cut-in/cut-out pressure settings. This switch serves as the Auto-On/Off positions for the unit.

Tank Safety Valve

Used to allow excess tank pressure to escape into the atmosphere. This valve should only open when the tank pressure is above the maximum rated pressure.

Pressure Relief Valve

The pressure relief valve located on the side of the pressure switch, is designed to automatically release compressed air when the air compressor reaches cut-out pressure. The released air should only escape momentarily and the valve should then close.

Pressure Relief Tube

Air Intake Filter

Provides clean air to the pump and must always be kept free of debris. Check on a daily basis or before each use.

Tank Drain Valve

Used to drain condensation from the air tank. Located at bottom of tank.

Tank Pressure Gauge

Indicates the reserve air pressure in the tank.

Outlet Tube

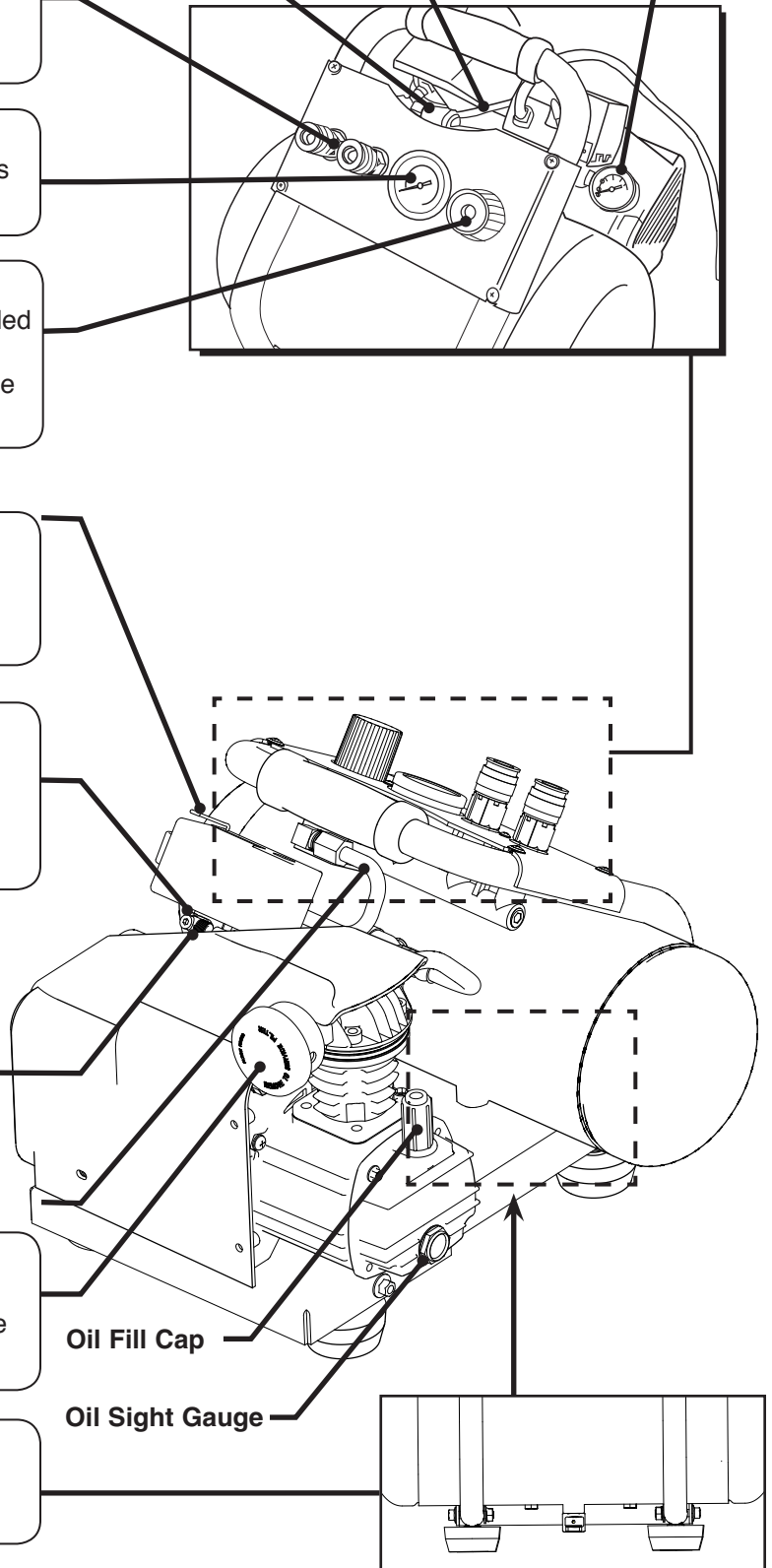

Installation & Assembly

⚠ WARNING

The air compressor should be turned off, unplugged from the power source, the air bled from the tank and the unit allowed time to cool before any maintenance is performed. Personal injuries could occur from moving parts, electrical sources, compressed air or hot surfaces. The quick connect assembly must be attached before use. Failure to assemble correctly could result in leaks and possible injury. If unsure of assembly instructions or you experience difficulty in the assembly please call your local service department for further instruction.

Assembly

1. Remove air compressor, oil bottle, intake filter, manual and accessories from the styrofoam.
2. Remove the plastic plug from the compressor intake port. (see diagram below)
3. Install the filter in the compressor intake port. (see diagram below)
4. Remove the oil fill cap from the crankcase and fill until the oil reaches the top of the red dot in the sight glass. Oil capacity is 3 oz. (see below) Use SAE-30 non-detergent (API CG/CD heavy duty motor oil). Under extreme cold weather conditions, 32° F (0°C) or below, use SAE-10 weight oil.
5. Replace the oil cap.
6. Attach the handle to the frame with the saddle bolts from the outside of the handle and the knobs on the inside.

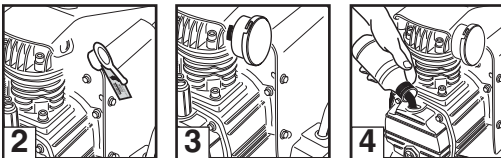

Estimated Assembly Time: Approximately 5 minutes

Getting Started - Location of the Air Compressor

The air compressor should always be located in a clean, dry and well ventilated environment. The unit should have at minimum, 12 inches of space on each side. The air filter intake should be free of any debris or obstructions. Check the air filter on a daily basis to make sure it is clean and in working order.

Grounding Instructions

This product should be grounded. In the event of an electrical short circuit, grounding reduces the risk of electric shock by providing an escape wire for the electric current.

This product is equipped with a cord having a grounding plug. (See the figure at top right corner.) The plug must be plugged into an outlet that is properly installed and grounded in accordance with all local codes and ordinances. Check with a qualified

electrician or service personnel if these instructions are not completely understood or if in doubt as to whether the tool is properly grounded.

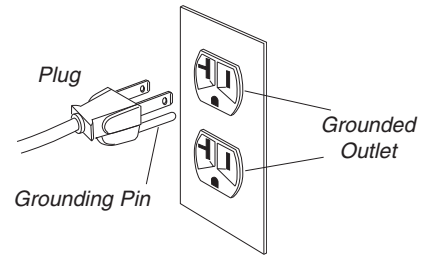

⚠ WARNING

Improper installation of the grounding plug will result in a risk of electric shock. If repair or replacement of the cord or plug is necessary, do not connect the grounding wire to either flat blade terminal. The wire with insulation having an outer surface that is green with or without yellow stripes is the grounding wire. Check with a qualified electrician or serviceman if the grounding instructions are not completely understood, or if in doubt as to whether the product is properly grounded. Do not modify the plug provided. If it will not fit the outlet, have the proper outlet installed by a qualified electrician.

This product is for use on a circuit having a nominal rating of 120 volts and is factory-equipped with a specific electric cord and plug to permit connection to a proper electric circuit. Make sure the product is connected to an outlet having the same configuration as the plug. An adapter should not be used with this product. If the product must be reconnected for use on a different type of electric circuit, qualified service personnel should make the reconnection.

Extension Cords

Use only a 3-wire extension cord that has a 3-blade grounding plug and a 3-slot receptacle that will accept the plug on the product. Make sure your extension cord is in good condition. When using an extension cord, be sure to use one heavy enough to carry the current your product will draw. Cords must not exceed 25 feet and No. 12 AWG size must be used. An undersized cord will cause a drop in line voltage resulting in loss of power and overheating.

Break In Procedures

No break in procedure is required by the user.

This product is factory tested to ensure proper operation and performance.

Operating Procedures

Daily Start-Up Procedures

1. Set the Auto-On/Off lever to the Off position.
2. Inspect the air compressor, air hose, and any accessories/tools being used for damage or obstruction. If any of these mentioned items are in need of repair/replacement, contact your local authorized service dealer before use.
3. Close the drain valve.
4. Check the oil level of the pump.
5. Connect the air hose to the quick connect socket on the regulator assembly by inserting the quick connect plug on the air hose into the quick connect socket. The quick connect socket collar will snap forward and lock the plug into place providing an air tight seal between the socket and plug. To release the air hose push the collar back on the quick connect socket.
6. Plug the power cord into the proper receptacle.
7. Turn the Auto-On/Off lever to the On-Auto position and the compressor will start and build air pressure in the tank to cut-out pressure and then shut off automatically.
8. Adjust the regulator to a PSI setting that is needed for your application and be sure it is within the safety standards required to perform the task. If using a pneumatic tool, the manufacturer should have recommendations in the manual for that particular tool on operating PSI settings.
9. The air compressor is now ready for use. The following inflation and cleaning accessories packaged with this unit should only be operated at maximum pressure of 90PSI: blow gun, rubber-tapered nozzle, inflation needles, adapter, and blow gun adapter.

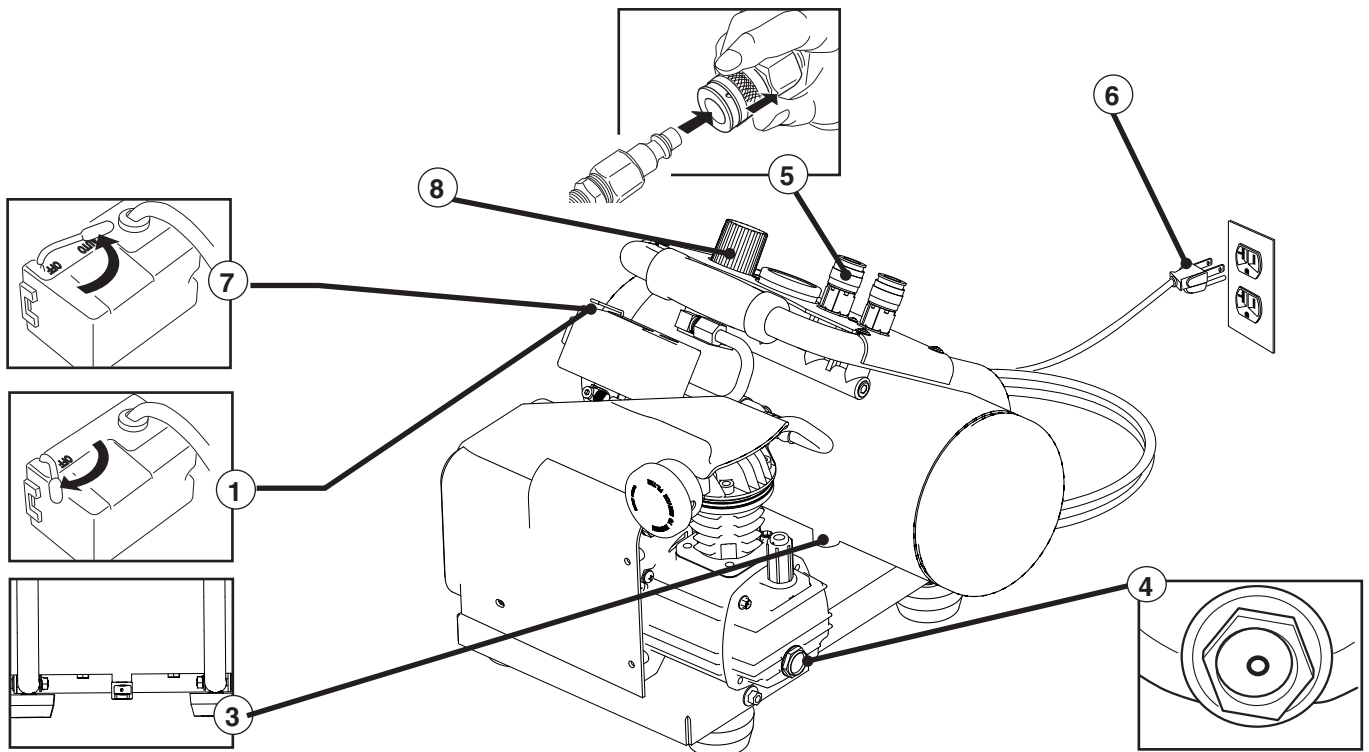

Daily Shut-Down Procedures

1. Set the Auto-On/Off lever to the Off position.
2. Unplug the power cord from the receptacle.
3. Set the outlet pressure to zero on the regulator.
4. Remove any air tools or accessories. When draining the tank, always use ear and eye protection. Drain the tank in a suitable location; condensation will be present in most cases of draining.
5. Open the drain valve allowing air to bleed from the tank. After all of the air has bled from the tank, close the drain valve to prevent debris buildup in the valve.

⚠ CAUTION

When draining the tank, always use ear and eye protection. Drain the tank in a suitable location; condensation will be present in most cases of draining.

⚠ WARNING

Water that remains in the tank during storage will corrode and weaken the air tank which could cause the tank to rupture. To avoid serious injury, be sure to drain the tank after each use or daily.

Maintenance

NOTE: Any service procedure not covered in the maintenance schedule should be performed by qualified service personnel.

WARNING

The air compressor should be turned off, unplugged from the power source, air bled from the tank and allowed time to cool before any maintenance is performed.

CAUTION

To ensure efficient operation and longer life of the air compressor unit, a routine maintenance schedule should be followed. The following schedule is geared toward a consumer whose compressor is used in a normal working environment on a daily basis.

Items to Check/Change	Before each use or daily
Check Tank Safety Valve	X
Overall Unit Visual Check	X
Check Air Filter	X
Drain Tank	X
Check Power Cord for Damage	X
Change Oil	after first 50 hours
	after every 100 hours
Check Oil Level	X

Storage

For storing the air compressor, be sure to do the following:

1. Turn the unit off and unplug the power cord from the receptacle.
2. Remove all air hoses, accessories, and air tools from the air compressor.
3. Perform the daily maintenance schedule.
4. Open the drain valve to bleed all air from the tank.
5. Close the drain valve.
6. Store the air compressor in a clean and dry location.

Troubleshooting Guide

⚠ WARNING The air compressor should be turned off and unplugged from the power source before any maintenance is performed as well as the air bled from the tank and the unit allowed time to cool. Personal injuries could occur from moving parts, electrical sources, compressed air, or hot surfaces.

PROBLEM	POSSIBLE CORRECTION
Air leaks at the check valve or at the pressure relief valve.	A defective check valve results in a constant air leak at the pressure relief valve when there is pressure in the tank and the compressor is shut off. Drain the tank, then remove and clean or replace the check valve.
Air leaks between head and cylinder.	Be sure of proper torque on head bolts. If leak remains, contact a service technician.
Air leak from safety valve.	Operate the safety valve manually by pulling on the ring. If the valve continues to leak when in the closed position, it should be replaced.
Pressure reading on the regulated pressure gauge drops when an accessory is used.	<p>If there is an excessive amount of pressure drop when the accessory is used, replace the regulator.</p> <p>NOTE: Adjust the regulated pressure under flow conditions (while accessory is being used). It is normal for the gauge to show minimal pressure loss during initial use of the tool.</p>
Excessive tank pressure.	Move the Auto-On/Off lever to the Off position. If the unit doesn't shut off, unplug it from the power source and contact a service technician.
Motor will not start.	Make sure power cord is plugged in and the switch is on. Inspect for the proper size fuse in your circuit box. If the fuse was tripped, reset it and restart the unit. If repeated tripping occurs, replace the check valve or contact a service technician.
Excessive moisture in the discharge air.	<p>Remove the water in the tank by draining after each use. High humidity environments will cause excessive condensation. Utilize water filters on your air line.</p> <p>NOTE: Water condensation is not caused by compressor malfunction. Be sure the compressor's air output is greater than your tool's air consumption rate.</p>
Air leaks from the tank body or tank welds.	Never drill into, weld or otherwise modify the air tank or it will weaken. The tank can rupture or explode. Compressor cannot be repaired. Discontinue use of the air compressor.

Air Compressor Model 15312

Parts List

